

SteamCub™ Plus

PRESSURELESS STEAM COOKER,
RETHEMALIZER & HOLDING CABINET

MODEL: 1SCE



Cleveland Standard Features

- Boilerless Pressureless Steam Cooker, Holding Cabinet and Rethermalizer.
- Capacity: Full Size Steam Table Pans:
 - Five: 2 1/2" x 12" x 20" (1/1 GN, 65mm)
 - Ten: 1" x 12" x 20" (1/1GN, 40mm)
- Easy installation, no drain line, water connections or hood is needed.*
- Programmable Preheat and Holding Cycle Temperature Controls with Compensating Thermostat.
 - Timer settings for 10 minute, 1 minute or 10 second intervals
 - Digital Time-Temperature and Low Water Indicator Display
- Three Versatile Operating Modes.
 - Steam and Hold
 - Holding Only: Preset at 160° F (71° C)
 - Constant Steaming
- 6" (152mm) Skid Resistant Stainless Steel Adjustable Legs with Flanged Feet.
- 8 gauge stainless steel inner cooking compartment, 14 gauge stainless steel outer compartment with two piece compartment door for an airtight, leak-proof seal.
- 9 kW total output, with easy to remove 1 kW heating elements (9ea) cast into aluminum blocks.
- Electronic Low-Water Shut-Off Safety Indicator with audible alarm, High Temperature Safety Shut-Off and LED "Heat On" Indicator Light.
- Separate Power ON/OFF Control includes an Automatic Pre-Heat when power is turned "ON".
- Easy-Access Manual Drain Valve located in front, Pan Slide Guides located under unit to fit 12" x 20" (1/1GN) Pans. Includes one 4" x 12" x 20
- Approvals: cUL, NSF #4.



Short Form Specifications

Shall be a Cleveland SteamCub Plus™, Model 1SCE, one compartment counter top steamer, holding cabinet and rethermalizer model number 1SCE. Electronic controls with three operating modes: constants steaming, steam-hold and holding only. 9 kW, 208 volts, 3 phase. Audible low water and high temperature safety indicator. 8 gauge stainless steel inner cooking compartment, 14 gauge stainless steel outer compartment with two piece compartment door.

Options & Accessories

- Equipment Stand Model UniStand34.
- POSK Pull-Out Shelf Kit for UniStands (P/N 111724)
- URK Pan Rack Kit UniStands (P/N 111726)
- Optional Voltages, 480 Volt (VOS2).
- 6 kW total Output Six - 1kW heating elements.
- Single Phase Operation.

* Consult local authorities for venting requirements

WATER QUALITY REQUIREMENT

The recommended minimum water quality standards whether untreated or pre-treated, based upon 10 hours of use per day, and a Daily Blowdown, are as follows:

TOTAL DISSOLVED SOLIDS	less than 60 parts per million
TOTAL ALKALINITY	less than 20 parts per million
SILICA	less than 13 parts per million
pH FACTOR	greater than 7.5
CHLORINE	less than 30 parts per million

Consult a local water treatment specialist for an on site water analysis for recommendations concerning steam generator feed water treatment (if required), in order to remove or reduce harmful concentrations of minerals. The use of highly mineralized water will mean that more frequent servicing of the steam generator will be necessary. The fact that a water supply is potable is not proof that it will be suitable for the generator.

- Compartment has capacity for:
Five, 12" x 20" x 2½" deep Cafeteria Pans.

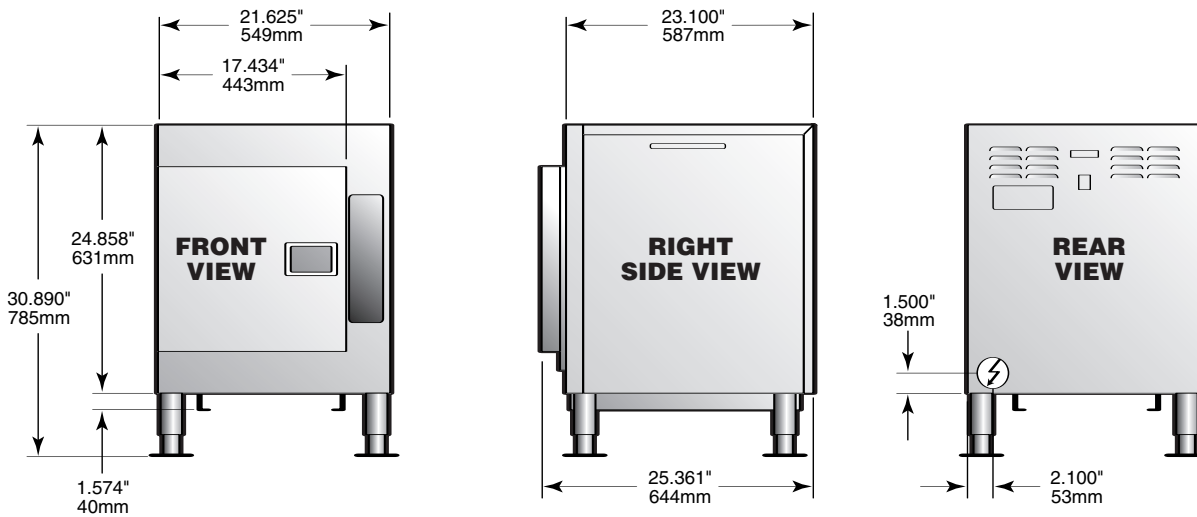

ELECTRICAL ⚡

WATTS	VOLTS	PHASE	WIRES	CYCLE HERTZ	AMPS	SUPPLY CONNECTION WIRE SIZE (COPPER)*	WATTS	VOLTS	PHASE	WIRES	CYCLE HERTZ	AMPS	SUPPLY CONNECTION WIRE SIZE (COPPER)*
Standard Wattage <i>Three Phase - 9 kW Standard</i>							Standard Wattage <i>Single Phase - 9 kW Standard</i>						
9400	208	3	3	60	26.1	10	9400	208	1	2	60	45.2	6
9400	240	3	3	60	22.6	10	9400	240	1	2	60	39.2	8
9400	480	3	3	60	11.4	14							
Optional Low Wattage <i>Three Phase - 6 kW option</i>							Optional Low Wattage <i>Single Phase - 6 kW option</i>						
6400	208	3	3	60	17.8	12	6400	208	1	2	60	30.8	8
6400	240	3	3	60	15.4	12	6400	240	1	2	60	26.7	10
6400	480	3	3	60	7.7	14							

* For supply connection use only copper wire suitable for at least 75°C. (167°F).

Note: Consult local authorities for venting and installation requirements.

* For supply connection use only copper wire suitable for at least 75°C (167°F).

NOTES:

Cleveland Range reserves right of design improvement or modification, as warranted. Many regional, state and local codes exist and it is the responsibility of the owner and installer to comply with the codes. Cleveland Range equipment is built to comply with applicable standards for manufacturers. Included among those approval agencies are U.L./NSF#4 and CSA (AGA, CGA).